

# Chapter 1

## Some Notation for Sets

A *set* is any collection of *objects*. Usually the objects we consider are things like numbers, points in the plane, geometrical figures, or functions. Sets are often described by listing the objects they contain inside curly braces, for example

$$\begin{aligned}A &= \{1, 2, 3, 4\}, \\B &= \{2, 3, 4\}, \\C &= \{4, 3, 3, 2\}, \\D &= \left\{1, \frac{1}{2}, \frac{1}{3}, \frac{1}{4}, \frac{1}{5}\right\}.\end{aligned}$$

There are a few sets that occur very often in mathematics, and that have special names:

$\mathbf{N}$	=	the set of all natural numbers = $\{0, 1, 2, 3, \dots\}$ .
$\mathbf{Z}$	=	the set of all integers = $\{0, -1, 1, -2, 2, \dots\}$ .
$\mathbf{Z}^+$	=	the set of all positive integers.
$\mathbf{Z}^-$	=	the set of all negative integers.
$\mathbf{R}$	=	the set of all real numbers.
$\mathbf{R}^+$	=	the set of all positive real numbers.
$\mathbf{R}^-$	=	the set of all negative real numbers.
$\mathbf{R}^2$	=	the set of all points in the plane.
$\mathbf{Q}$	=	the set of all rational numbers.
$\mathbf{Q}^+$	=	the set of all positive rational numbers.
$\mathbf{Q}^-$	=	the set of all negative rational numbers.
$\emptyset$	=	the empty set = the set containing no elements.

A rational number is a number that can be expressed as a quotient of two integers. Thus a real number  $x$  is rational if and only if there exist integers  $a$  and  $b$  with  $b \neq 0$  such that  $x = a/b$ .

The terms “point in the plane” and “ordered pair of real numbers” are taken to be synonymous. I assume that you are familiar with the usual representation of points in the plane by pairs of numbers, and the usual way of representing geometrical objects by equations and inequalities.

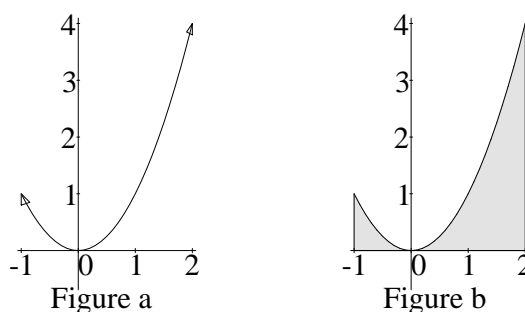

Thus the set of points  $(x, y)$  such that  $y = x^2$  is represented in figure a, and the set of points  $(x, y)$  such that  $-1 \leq x \leq 2$  and  $0 \leq y \leq x^2$  is represented in figure b. The arrowheads in figure a indicate that only part of the figure has been drawn.

The objects in a set  $S$  are called *elements of  $S$*  or *points in  $S$* . If  $x$  is an object and  $S$  is a set then

$$x \in S \text{ means that } x \text{ is an element of } S,$$

and

$$x \notin S \text{ means that } x \text{ is not an element of } S.$$

Thus in the examples above

$$\begin{array}{llll} 2 \in A. & 2/6 \in D. & 1 \notin C. & 0 \notin \mathbf{Z}^+. \\ 0 \notin \emptyset. & \emptyset \notin A. & 6/3 \in \mathbf{N}. & 0 \in \mathbf{N}. \end{array}$$

To see that  $\emptyset \notin A$ , observe that  $A$  has exactly four elements, and none of these elements is  $\emptyset$ .

Let  $S$  and  $T$  be sets. We say that  $S$  is a *subset* of  $T$  and write  $S \subset T$  if and only if every element in  $S$  is also in  $T$ . Two sets are considered to be equal if and only if they have exactly the same elements. Thus

$$S = T \text{ means } (S \subset T \text{ and } T \subset S).$$

You can show that two sets are *not* equal, by finding an element in one of the sets that is not in the other.

In the examples above,  $B \subset A$  and  $B = C$ . For every set  $S$  we have

$$S \subset S \text{ and } \emptyset \subset S.$$

Also

$$\begin{array}{ll} 1 \in \{1, 2, 3\}. & \emptyset \notin \{1, 2, 3\}. \\ \{1\} \subset \{1\}. & \emptyset \subset \{1, 2, 3\}. \\ \{1\} \notin \{1\}. & 1 \in \{1\}. \end{array}$$

The idea of set was introduced into mathematics by Georg Cantor near the end of the nineteenth century. Since then it has become one of the most important ideas in mathematics. In these notes we use very little from the *theory* of sets, but the *language* of sets will be very evident.

**1.1 Definition (Box, width, height, area.)** Let  $a, b, c, d$  be real numbers with  $a \leq b$  and  $c \leq d$ . We define the set  $B(a, b; c, d)$  by

$$B(a, b; c, d) = \text{the set of points } (x, y) \text{ in } \mathbf{R}^2 \text{ such that} \\ a \leq x \leq b \text{ and } c \leq y \leq d.$$

A set of this type will be called a *box*. If  $R = B(a, b; c, d)$ , then we will refer to the number  $b - a$  as the *width* of  $R$ , and we refer to  $d - c$  as the *height* of  $R$ .

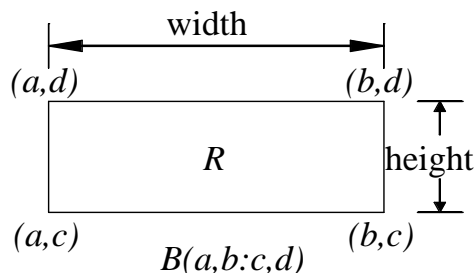

The *area* of the box  $B(a, b : c, d)$  is the number

$$\text{area}(B(a, b : c, d)) = (b - a)(d - c).$$

**Remark:** Notice that in the definition of box, the inequalities are “ $\leq$ ” and not “ $<$ ”. The choice of which sort of inequality to use is somewhat arbitrary, but some of the assertions we will be making about boxes would turn out to be false if the boxes did not contain their boundaries.

In Euclid’s geometry no distinction is made between sets that contain their boundaries and sets that do not. In fact the early Greek geometers did not think in terms of sets at all. Aristotle maintained that

A line cannot be made up of points, seeing that a line is a continuous thing, and a point is indivisible[25, page 123].

The notion that geometric figures are sets of points is a very modern one. Also the idea that area is a *number* has no counterpart in Euclid’s geometry, and in fact Euclid does not talk about area at all. He makes statements like

Triangles which are on equal bases and in the same parallels are equal to one another[17, vol I page 333].

We interpret “are equal to one another” to mean “have equal areas”, but Euclid does not define “equal” or mention “area”.

**1.2 Definition (Unions and Intersections.)** Let  $F = \{S_1, \dots, S_n\}$  be a set of sets. The *union* of the sets  $S_1, \dots, S_n$  is defined to be the set of all points  $x$  that belong to at least one of the sets  $S_1, \dots, S_n$ . This union is denoted by

$$S_1 \cup S_2 \cup \dots \cup S_n$$

or by

$$\bigcup_{i=1}^n S_i. \tag{1.3}$$

The *intersection* of the sets  $S_1, S_2, \dots, S_n$  is defined to be the set of points  $x$  that are in every one of the sets  $S_i$ . This intersection is denoted by

$$S_1 \cap S_2 \cap \dots \cap S_n$$

or by

$$\bigcap_{i=1}^n S_i. \tag{1.4}$$

The index  $i$  in equations 1.3 and 1.4 is called a *dummy index* and it can be replaced by any symbol that does not have a meaning assigned to it. Thus,

$$\bigcup_{i=1}^n S_i = \bigcup_{k=1}^n S_k = \bigcup_{t=1}^n S_t,$$

but expressions such as  $\bigcup_{n=1}^n S_n$  or  $\bigcup_{3=1}^n S_3$  will be considered to be ungrammatical.

**1.5 Example.** For  $i \in \mathbf{Z}^+$  let  $R_i = B(i, i + \frac{3}{2} : -\frac{1}{i}, \frac{1}{i})$ . Then  $\bigcup_{i=1}^4 R_i$  is represented in the figure, and  $\bigcap_{i=1}^4 R_i = \emptyset$ . Also  $R_1 \cap R_2 = B(2, \frac{5}{2} : -\frac{1}{2}, \frac{1}{2})$ .

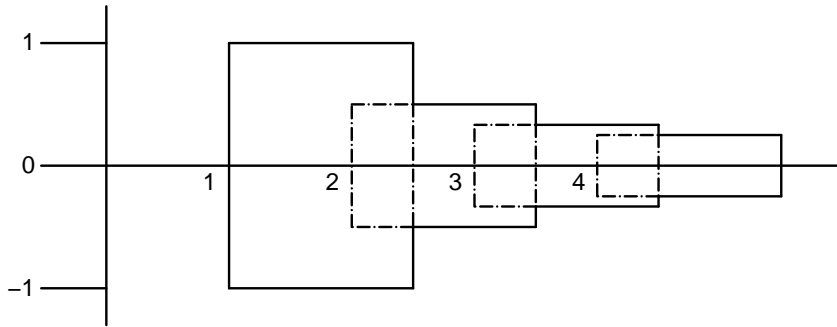

In the figure below,

$$B(0, 4 : 0, 2) \cap B(1, 5 : -1, 1) \cap B(2, 3 : -2, 3) = B(2, 3 : 0, 1).$$

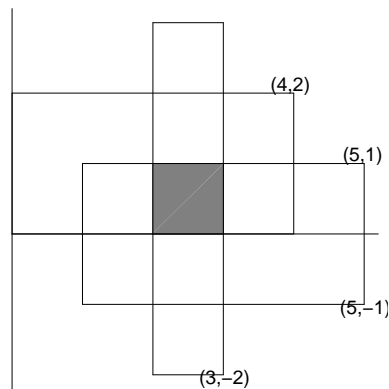

**1.6 Definition (Set difference.)** If  $A$  and  $B$  are sets then the *set difference*  $A \setminus B$  is the set of all points that are in  $A$  but not in  $B$ .

In the figure, the shaded region represents  $B(2, 4: 0, 4) \setminus B(3, 5: -1, 3)$ .

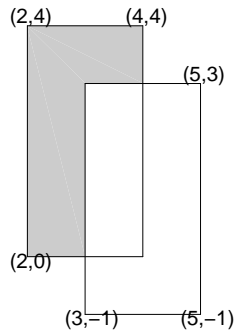

**1.7 Exercise.** Explain why it is *not* true that

$$B(2, 4: 0, 4) \setminus B(3, 5: -1, 3) = B(2, 3: 0, 4) \cup B(3, 4: 3, 4).$$

I will often use set relations such as

$$A \cup B = (A \setminus B) \cup B$$

or

$$A = (A \setminus B) \cup (A \cap B)$$

without explanation or justification. The second statement says that  $A$  consists of the points in  $A$  which are not in  $B$  together with the points in  $A$  that are in  $B$ , and I take this and similar statements to be clear.

**1.8 Definition (Intervals.)** Let  $a, b$  be real numbers with  $a \leq b$ . We define the following subsets of  $\mathbf{R}$ :

- $(a, b)$  = the set of real numbers  $x$  such that  $a < x < b$ .
- $(a, b]$  = the set of real numbers  $x$  such that  $a < x \leq b$ .
- $[a, b)$  = the set of real numbers  $x$  such that  $a \leq x < b$ .
- $[a, b]$  = the set of real numbers  $x$  such that  $a \leq x \leq b$ .
- $(a, \infty)$  = the set of real numbers  $x$  such that  $x > a$ .

- $[a, \infty)$  = the set of real numbers  $x$  such that  $x \geq a$ .
- $(-\infty, a)$  = the set of real numbers  $x$  such that  $x < a$ .
- $(-\infty, a]$  = the set of real numbers  $x$  such that  $x \leq a$ .
- $(-\infty, \infty)$  = the set of real numbers.

A subset of  $\mathbf{R}$  is called an *interval* if it is equal to a set of one of these nine types. Note that  $(a, a) = \emptyset$  and  $[a, a] = \{a\}$ , so the empty set and a set consisting of just one point are both intervals.

**1.9 Definition (End points: open and closed intervals.)** If  $I$  is a non-empty interval of one of the first four types in the above list, then we will say that the *end points* of  $I$  are the numbers  $a$  and  $b$ . If  $I$  is an interval of one of the next four types, then  $I$  has the unique end point  $a$ . The empty set and the interval  $(-\infty, \infty)$  have no end points. An interval is *closed* if it contains all of its end points, and it is *open* if it contains none of its end points.

**1.10 Exercise.** Let  $a, b$  be real numbers with  $a < b$ . For each of the nine types of interval described in definition 1.8, decide whether an interval of the type is open or closed. (Note that some types are both open and closed, and some types are neither open nor closed.) Is the interval  $(0, 0]$  open? Is it closed? What about the interval  $[0, 0]$ ?

**1.11 Exercise.** In the figure below,  $A$ ,  $C$ , and  $F$  are boxes.

- a) Express each of  $A$ ,  $C$ ,  $F$  in the form  $B(?, ? :?, ?)$ .
- b) Express  $D$ ,  $E$ , and  $A \cap C$  as intersections or unions or set differences of boxes. The dotted edge of  $E$  indicates that the edge is missing from the set.
- c) Find a box that contains  $A \cup C$ .

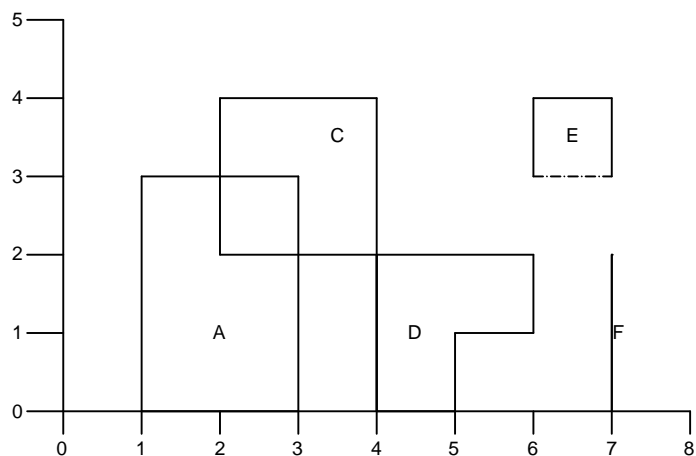

**1.12 Exercise.** Let  $S$  be the set of points  $(x, y)$  in  $\mathbf{R}^2$  such that  $1 \leq x \leq 4$  and  $0 \leq y \leq \frac{1}{x^2}$ . Let  $T$  be the set of points  $(x, y)$  in  $\mathbf{R}^2$  such that

$$(x, y) \in B(-1, 1 : -1, 1) \text{ and } xy > 0.$$

Make sketches of the sets  $S$  and  $T$ .

**1.13 Exercise.** Describe the sets  $S$  and  $T$  below in terms of unions or intersections or differences of boxes.

